

# ROADIE 15L CAR FRIDGE

## Owners Manual & Operating Instructions

MODEL SC15: 12V / 24V



Please read carefully  
before use and  
installation



## Important Information

- Do not lay your Bushman on its back or sides or at any angle exceeding 30°.
- Never operate your Bushman directly from 240V mains power without using a 240V – 12V adapter.
- Do not use a modified sine wave inverter to operate your Bushman.

## Fitting The Tie-Down Brackets

1. Before fitting the tie-down brackets, please put the transit cover on the fridge. The transit cover has cut-outs for the position of the tie-down brackets.
2. Position the tie down brackets on each end of the fridge cabinet and align using a spirit level. You can hold them in place with masking tape.
3. Mark the position of the 4 holes.
4. Remove the tie-down brackets and drill 3mm pilot holes through the sheet metal.
5. Affix the tie down brackets using the 8 screws provided. Do not over tighten the screws.

## 12V Installation

### 6MM WIRING DIRECT TO BATTERY

Having a good power supply is key to your Bushman operating at its best. For optimum results, we recommend using minimum 6mm automotive wire directly from your 12V power outlet to your cars battery through a 10 Amp fuse. Ensure the earth is wired back to your battery, not to the chassis. If your wiring is not minimum 6mm or is not direct to your battery, your Bushman may cut out early due to power drop in your wiring.

## Using a Generator

Only use a high quality pure sine wave generator to operate your Bushman. Fluctuations in generator current will damage the refrigerator. For fail safe operation with a generator we recommend running a battery charger from your generator outlet to a 12V battery, and then running your Bushman directly from the battery.

## Reversing The Lid

To change the opening direction of the lid, remove the 2 plastic hinge recess covers from the non-hinged side. You will need to drill a small hole into each cover and pry them off gently. Swap the hinges across. There are two extra plastic covers provided with each new fridge to cover the existing recesses.

## Safe Operation

### VENTILATION

Always allow sufficient air ventilation around the front and sides of the compressor compartment. This will ensure heat can escape easily from the compressor and condensor.

### NORMAL OPERATING SOUNDS

You may hear faint gurgling, bubbling or whirring sounds when your Bushman is running. This is normal as the refrigerant is being pumped through the refrigerant coils.

### DELAYED STARTUP

Due to the latest compressor technology, your fridge may take up to 60 seconds to start after being powered up or after the temperature settings are altered.

### CORRUGATIONS / PACKING

If you are using your fridge whilst driving on corrugated or rough roads, ensure that your goods are packed in a way that no hard objects are rubbing on the inside of the fridge cabinet. This may permanently damage your fridge.

### MOUNTING

You can mount your fridge using the 4 nutserts on the bottom of the fridge. We recommend affixing the supplied 4 rubber feet to absorb shocks in this scenario.

### CYCLE TIMES

When your Bushman is running it will operate at 2°C either side of set temperature. For example, with your Bushman set at 0°C the compressor will operate until the fridge reaches -2°C. The compressor will cut back in when the fridge temperature reaches +2°C.

By running 2°C either side of the set temperature the compressor will not cut in and out excessively and this will reduce your power consumption.

## Cleaning

### INTERNAL CLEANING

Wash the inside of your Bushman with luke warm water and a mild soap. Never use abrasive or corrosive cleaning agents, steel wool or scouring sponges. A sponge, towel, or soft brush is recommended. After cleaning, thoroughly rinse and dry.

# Trouble Shooting

## Beep / Flashing Light

The Roadie is fitted with a small internal speaker. If your compressor notices an error, after a minute it will start to beep and the blue LED will flash.

NO. OF BEEPS/ FLASHES	ERRORS
1	<b>Battery protection cut-out</b> The voltage is outside the cut-out setting, Refer to VOLTAGE ISSUES below.
2	<b>A) Too many start attempts</b> After multiple failed attempts to start due to low voltage <b>B) Fan over current cut-out</b> The fan loads the electronic unit with more than 0.5 A avg Refer to VOLTAGE ISSUES below.
3	<b>Motor start error</b> The rotor is blocked or the differential pressure in the refrigeration system is too high (>5 bar). Contact BUSHMAN.
4	<b>Minimum motor speed error</b> Refrigeration system is too heavily loaded. Motor cannot maintain minimum speed approx 1,850 rpm. Contact BUSHMAN.
5	<b>Thermal cut-out of electronic unit</b> Refrigeration system too heavily loaded or ambient temperature is high. Electronic unit will run too hot. Contact BUSHMAN.
6	<b>Thermostat failure</b> If the NTC thermistor is short-circuit or has no connection. Contact BUSHMAN.

## Voltage Issues

Your Bushman needs a minimum 10.9V to start and 9.6V to continue operating.

During startup a load is placed on the power supply and voltage can drop by as much as 2V – 3V, especially if the wiring is insufficient (less than 6mm direct to battery) or if there is a loose connection somewhere.

If this occurs when you try and start your Bushman and the power supply drops under 10.9V it will not start. If this occurs when your Bushman is running and the power supply drops below 9.6V it will stop.

## Common 12V Power Supply Issues

### WIRING

Often the standard wiring from the car battery to the 12V outlet is too small. A minimum 6mm automotive wiring should be used and the earth should be wired directly back to the battery.

### BATTERY

The car battery could be old, undersized or have a dead cell causing too much voltage drop.

### CONNECTIONS

The 12V plug, car 12V socket or any of the connections between the fridge and the battery could be faulty or have come loose since installation.

## Troubleshooting Flow Chart

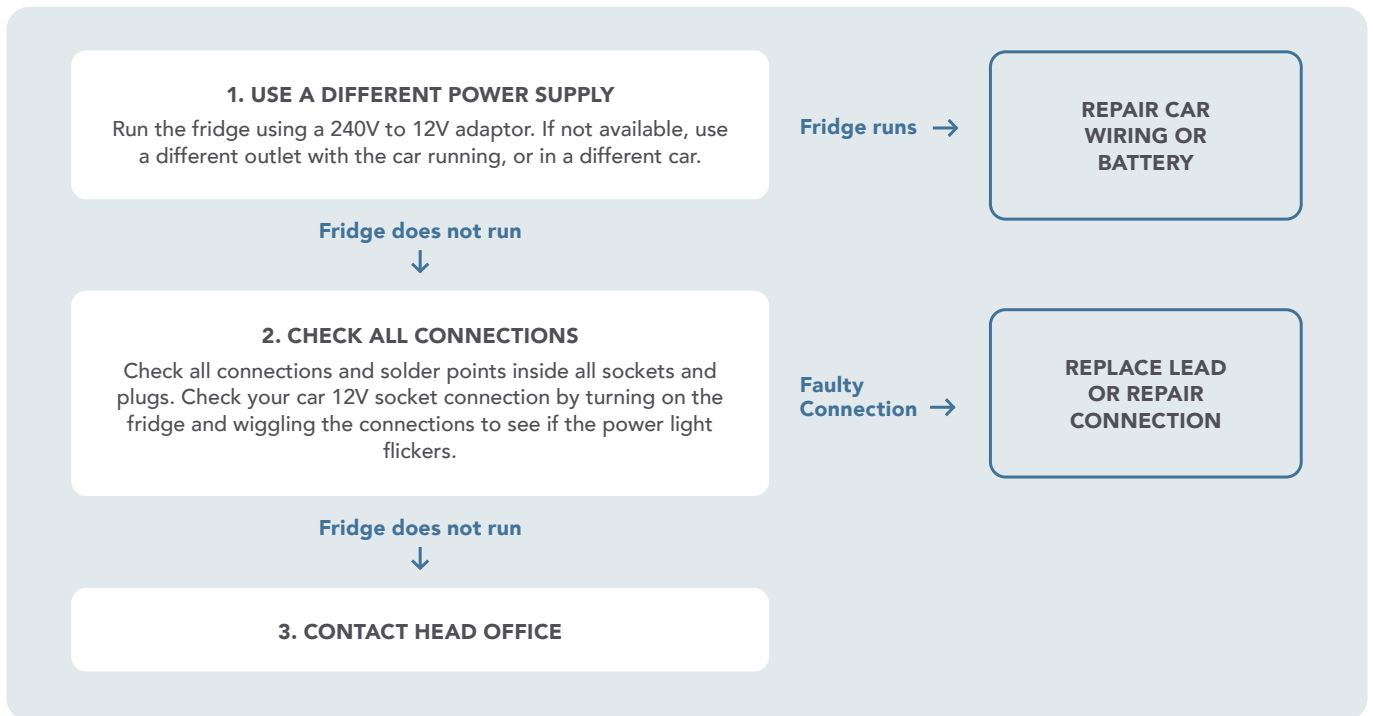

## Measurements

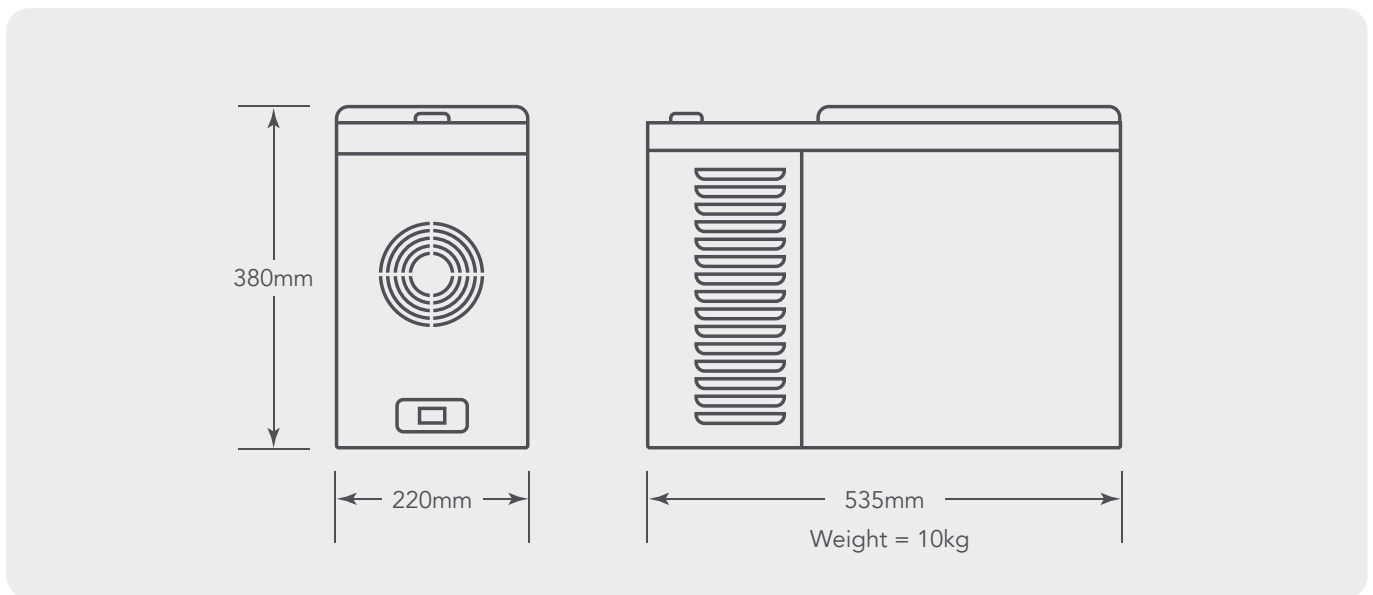

## Warranty

DP Refrigeration trading as Bushman Fridges ABN 94 615 295 255 (Bushman) warrants, to the original owner, that this product is free from defects in workmanship and material for a period of three years from the purchase date. This warranty shall be limited to repairing or replacing, at Bushman's option and without charge to the purchaser, defective components. All warranty work shall be performed at a Bushman approved facility. Shipping charges related to returning the product to the bushman facility are not covered under this warranty. However, this warranty covers shipping charges related to returning the repaired product to the customer.

This warranty does not apply to damage or wear to the product caused by accident, abuse, misuse, neglect, unauthorized alteration or repair, or if the product was not installed in accordance with Bushman printed installation and operating instructions. To obtain service under this warranty, the defective product must be returned to Bushman in clean condition together with original purchase receipt. Any product repaired or replaced under this warranty will be warranted for the balance of the warranty period with respect to the original purchased product.



**BUSHMAN**

| [BUSHMAN.COM.AU](http://BUSHMAN.COM.AU)

| **T** +61 3 8080 9990

| **E** [info@bushman.com.au](mailto:info@bushman.com.au)