

DF30-HD

30L 12V / 24V
Drawer Fridge Freezer

Owners Manual & Operating Instructions

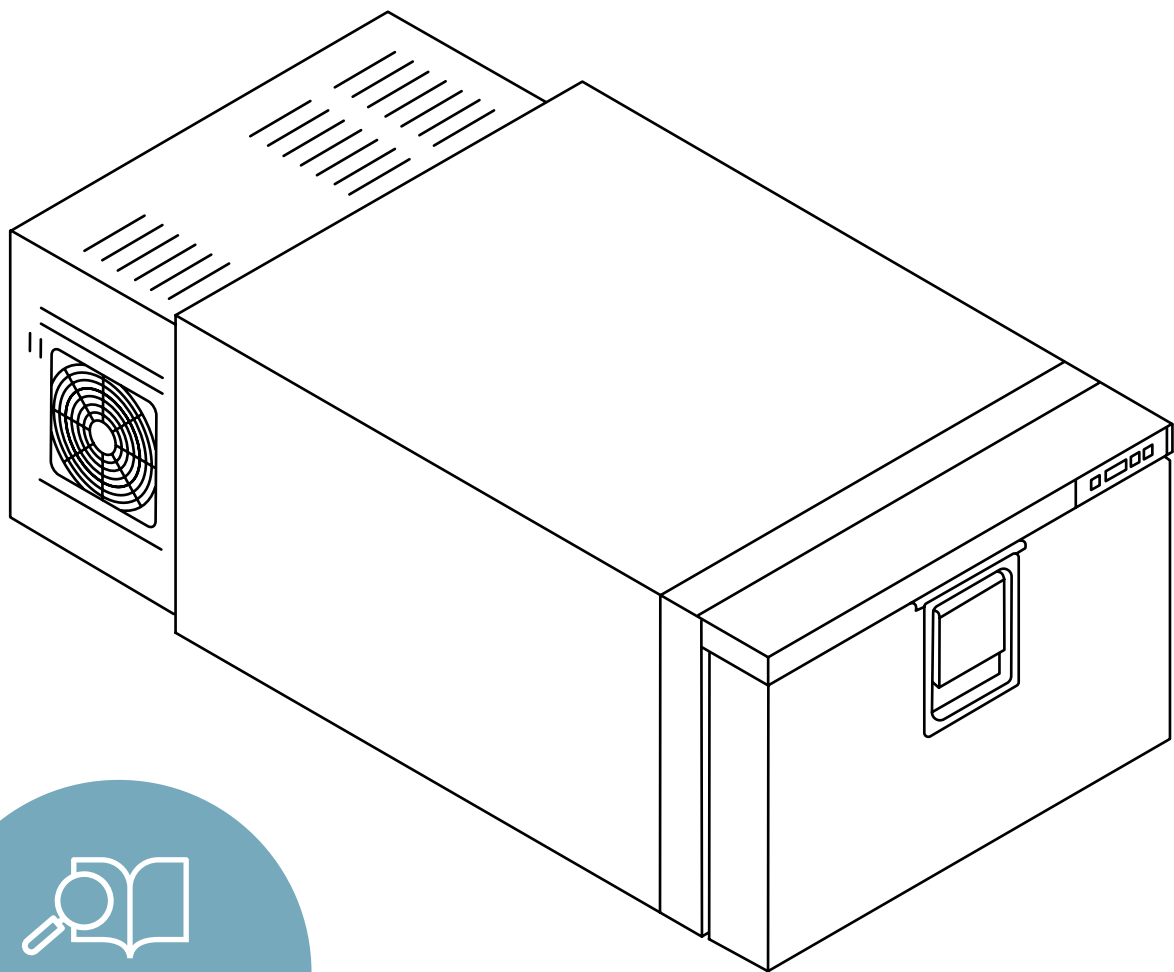

Please read carefully
before use and
installation



100% AUSSIE OWNED
FAMILY COMPANY

EST 1982

Congratulations on your purchase of a Bushman DF30-HD. Please read these instructions carefully before installation and use.

Warnings

- This appliance is not intended for use by persons (including children) with reduced physical, sensory or mental capabilities, or lack of experience and knowledge, unless they have been given supervision or instruction concerning use of the appliance by a person responsible for their safety.
- Children should be supervised to ensure they do not play with the appliance.
- The instructions for Class III appliances shall state that it must only be supplied at safety extra-low voltage corresponding to the marking on the appliance.
- This appliance is suitable for camping use.
- Do not expose the appliance to rain.
- Do not store explosive substances such as flammable – propellant in this appliance.
- Do not store explosive substances such as aerosol cans with a flammable propellant in this appliance.
- Keep ventilation openings in the appliance enclosure or in the built-in structure clear of obstruction.
- Do not use mechanical devices or other means to accelerate the defrosting process, other than those recommended by the manufacturer.
- Do not use electrical appliances inside the food storage compartments of the appliance, other than those recommended by the manufacturer.
- Do not damage the refrigerant circuit.

Important information

- Please do not lay your fridge on its back, top or sides or at any angle exceeding 30°. If your fridge has been handled this way, stand the fridge upright for 12 hrs to allow the internal fluids to redistribute evenly before use.
- Never operate your fridge directly from a 240 V or AC power supply.
- Do not use a modified sine wave inverter to operate your fridge.

Prior to installation

Delivery

At delivery, please check that the fridge is complete and is not damaged in any way. Remove all packaging and securing tapes from the fridge. Do not connect an appliance that has been damaged, contact Bushman immediately.

Installation

Installation of the DF30-HD must be completed by a suitably trained professional only.

Power supply

Your fridge must be connected to a stable and regulated 12 V or 24 V DC power supply only. The compressor will automatically detect which voltage is present and adjust accordingly.

Wiring

Always wire your fridge directly to your battery terminals. Do not run the wires on a shared circuit, via a buss bar or battery management system. Please also ensure the negative wire is wired directly to your battery, not to a chassis. If the power cord is damaged, it must be replaced by the manufacturer, a service agent or similarly qualified persons to avoid hazard.

Ensure the wiring polarity is correct. Connect the red wire to the positive terminal (+) and the white wire to the negative terminal (-). Never connect bare electric wires. Use only connections of a size suitable for the cross section of the wire being used.

CROSS SECTION IN MM ²	AWG (AMERICAN WIRE GAUGE)	MAXIMUM LENGTH OF WIRE IN METRES	
		12 V	24 V
2.5	13	2.5	5
4	12	4	8
6	10	6	12
10	8	10	20

Isolation switch and fuse

We recommend installing an isolation switch for the fridge circuit as close to your battery bank as possible. Any switches must have a breaking load not less than 20 A on 12 V or 10 A on 24 V.

The power supply wiring must also be protected with a 15 A fuse.

Installation in a cavity

To avoid a hazard due to instability of the appliance it must be fixed in accordance with these instructions. Your new fridge is designed to be installed in a cavity. We recommend allowing a minimum 5mm gap on each side and the top for ease of installation. A minimum gap of 40mm is required for the rear. Refer to the following table for the recommended cut-out dimensions.

MODEL	CUT-OUT CAVITY DIMENSIONS (MM)		
	WIDTH	DEPTH	HEIGHT
DF30	445	880	315

Mounting option 1 – Internal sleeves

There are 2 internal mounting sleeves on the inside of the fridge cabinet. Access is provided by removing the plastic tub. Gently lever off the plastic caps. M5 screws or bolts need to be used. Drill 4mm pilot holes through the plastic sleeve and right through the fridge cabinet sides. Put a small nylon washer onto the screw / bolt heads before inserting. Ensure that the exterior of the fridge cabinet is flush with your cabinetwork before affixing the screws / bolts. If there is a gap, pack it out with a suitable hard material. Check for screw / bolt tightness after your first trip.

Mounting option 2 – External threaded nut inserts

There are 4 external M6 threaded nut inserts which can be used for affixing the fridge. Please only insert a bolt up to 15mm into the nut insert.

Ventilation

Ventilation will have a critical impact on the efficient operation of your fridge. A minimum of 2 vents needs to be provided from the rear of the fridge cavity to the outside environment, or to the main room where the fridge is located. The vents should be located at each side of the fridge cavity, or at one side and the top. The vents must have a free cross section of 300cm² each. Note that a 400mm x 200mm fluted vent has a free cross section of approximately 400 cm² (not 800 cm²).

Operating The Fridge

ON/OFF Toggles the fridge between "standby" and "power on" modes.

PLUS / MINUS Increase or decrease the set temperature (-18°C to 6°C).

In Standby mode, the screen is blank.

In Power on mode, the screen displays the fridge temperature.

Equalising the fridge

During the first 24 hours of operation, your compressor will operate for longer than usual. This process allows the internal air temperature, food, drinks, condenser, compressor, and insulation to equalise.

Keep hot / wet items out of the fridge

Try and keep hot or wet items out of the fridge as they are a prime source of moisture and ice build-up.

Rubber seals are clean

Keep your rubber seals clean and free from stickiness. You can clean the rubber seals and the front edge of the fridge cabinet with warm, soapy water.

Have goods inside the fridge

The fridge will not operate properly if it is empty, as air does not hold temperature well. If you are using a wireless thermometer the temperature readout will fluctuate significantly with the changes in air temperature, whilst your goods inside the fridge will not vary as much.

Defrosting

Defrosting needs to be carried out when the ice layer reaches a thickness of 5 - 10mm.

Turn off the power to the fridge and move your food and beverages to another cool place. Do not use any objects to remove the ice or frost, it must be allowed to melt naturally. Once the ice has melted, thoroughly dry the inside of the fridge and freezer compartment. Re-start the fridge and monitor after 24 hours.

Cleaning

Wash the inside of your fridge with a soft cloth, lukewarm water, and a mild soap. Never use abrasive or corrosive cleaning agents, steel wool, scouring sponges or scrapers of any kind.

Storage

When the fridge is not in use, please disconnect power to the fridge completely. Keep the door of the fridge ajar when the fridge is not in use, to allow fresh air to circulate inside the fridge.

Trouble shooting

Please check each of these 3 points. All 3 need to be right for your fridge to operate correctly.

Voltage

The most common cause of an incorrectly functioning fridge, or a fridge that starts and stops and doesn't get cold, is a lack of consistent voltage. Secop compressors have built in battery protection and need the following minimum default voltage for the compressor to start (Cut-in) or continue running (Cut-out).

VOLTAGE	CUT OUT	CUT IN
12V	9.6 V	10.9 V
24V	21.3 V	22.7 V

Note that when the compressor starts it will draw approximately 10A for 1/2 second to turn the compressor over. When this 10A load is applied, the voltage can easily drop by up to 5V, causing the compressor to turn off again.

This often happens at night when the battery gets a bit lower (no solar input) or when the car alternator hasn't been started for a while (no alternator input) or if there is a weak spot somewhere in the electrical system (weak join, weak solder, undersized wire, worn battery).

To isolate this problem, use a different, direct power supply

Connect the red and white power wires from the compressor directly to a different 12V power source (for example a fully charged deep cycle 12V battery). It is important to run these two wires directly to the power source, without any unnecessary connections, plugs, solar, battery management, power distribution or buss bars. If the fridge now runs correctly, there is a power supply issue somewhere.

Get an electrician to check

- The polarity of the connections are correct
- The wiring between the fridge and battery is correctly sized
- Any connections or joins in the wire between the fridge and the power source are 100%
- The battery is not wearing out and is capable of consistently providing 12 volts when a 10 amp load is placed on it
- The voltage to the compressor is still 12V when a 10 A load is placed on the wires

Ventilation and air-flow

- There is adequate ventilation and free air flow to the compressor area
- The fridge is not installed in a sealed cavity, container or canopy
- The condensor fan is operating

Ice build up

Ice may slowly build up on the inside of the fridge wall over many weeks. This is a normal part of the operation of a low-power cooling system. Excessive ice build-up is a problem as the ice eventually insulates the cooling element and hinders the fridge's ability to cool. In this instance, please defrost your fridge by turning it off and allowing the melted ice to drain via the drain hose.

Error codes

CODE	DESCRIPTION
E1	Battery protection cut-out The voltage is outside the cut-out setting.
E2	Too many start attempts (or fan over current) This generally indicates the compressor has had too many start attempts due to low voltage cut-out. It could also indicate fan overload of more than 0.5A but this is extremely rare.
E3	Motor speed error The rotor is blocked or the pressure in the refrigeration system is too high (>5 bar)
E4	Minimum motor start error Refrigeration system is overloaded, and motor cannot maintain minimum speed (1850 rpm)
E5	Thermal cut-out Refrigeration system overloaded or ambient temperature is too high.
E7	Thermostat failure When the thermistor fails, the compressor runs 20min on / 20 min off.
E8	Door open The door has been open for more than 2 minutes
E9	Tilt angle exceeds 30° The fridge tilt angle exceeded 30°. This code clears 5 minutes after the tilt angle reduces to below 30

Technical specifications

COMPRESSOR	SECOP BD35HD
VOLTAGE	12 V / 24 V DC
MAX CURRENT	7.5A / 3.75A
POWER	60 W
REFRIGERANT	R134A (120G)
EXTERNAL DIMENSIONS (MM)	W 440 D 840 H 310
NETT WEIGHT	24KG
CLIMATIC CLASS	T

Warranty

DP Refrigeration Pty Ltd trading as Bushman Fridges ABN 94 615 295 255 (Bushman) warrants, to the original owner, that this product is free from defects in workmanship and material for a period of three (3) years from the purchase date and seven (7) years for the compressor only. This warranty shall be limited to repairing or replacing, at Bushman's option and without charge to the purchaser, defective components. All warranty work shall be performed at a Bushman approved facility. Shipping charges related to returning the product to the Bushman facility are not covered under this warranty. However, this warranty covers shipping charges related to returning the repaired product to the customer. This warranty does not apply to damage or wear to the product caused by accident, abuse, misuse, neglect, unauthorized alteration or repair, or if the product was not used in accordance with Bushman printed installation and operating instructions. To obtain service under this warranty, the defective product must be returned to Bushman together with a copy of the original purchase receipt. Any product repaired or replaced under this warranty will be warranted for the balance of the warranty period with respect to the original purchased product. Bushman is not liable for any incidental or consequential loss or damages whatsoever as a result of use or misuse of this product. Any statutory warranty also applies.

DF-30 HD Installation

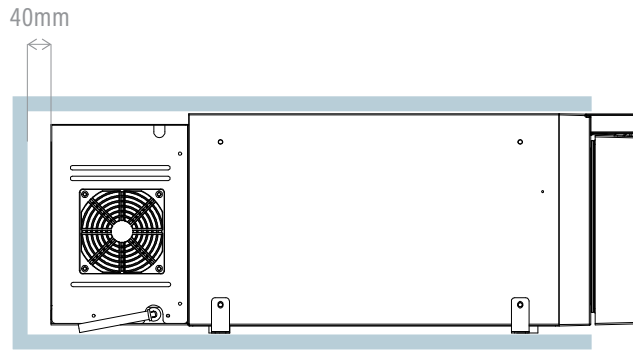

Rear gap requirement

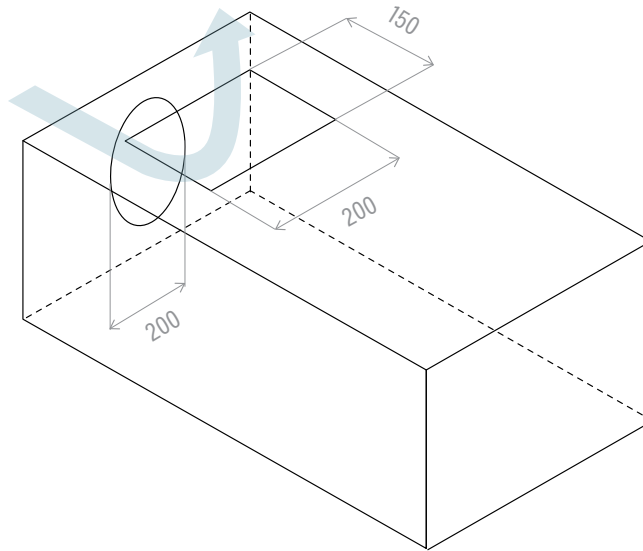

Interior ventilation option 1 - Top and back (rectangle or circle) at rear

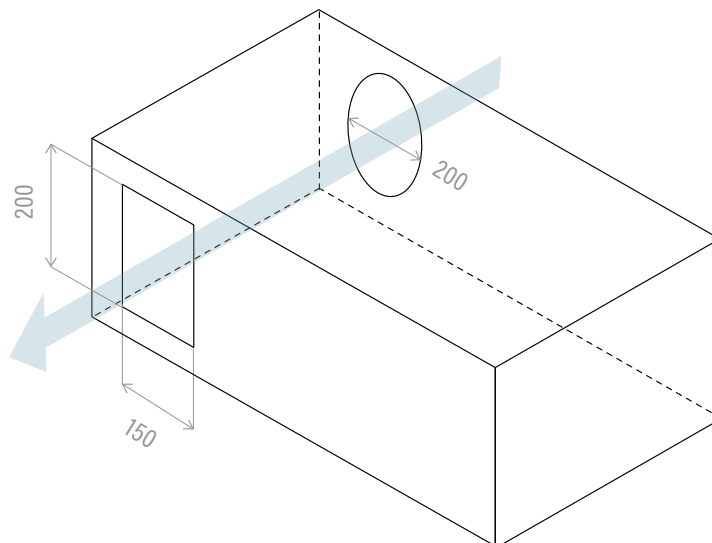

Interior ventilation option 2 - Both sides (rectangle or circle) at rear

Measurements

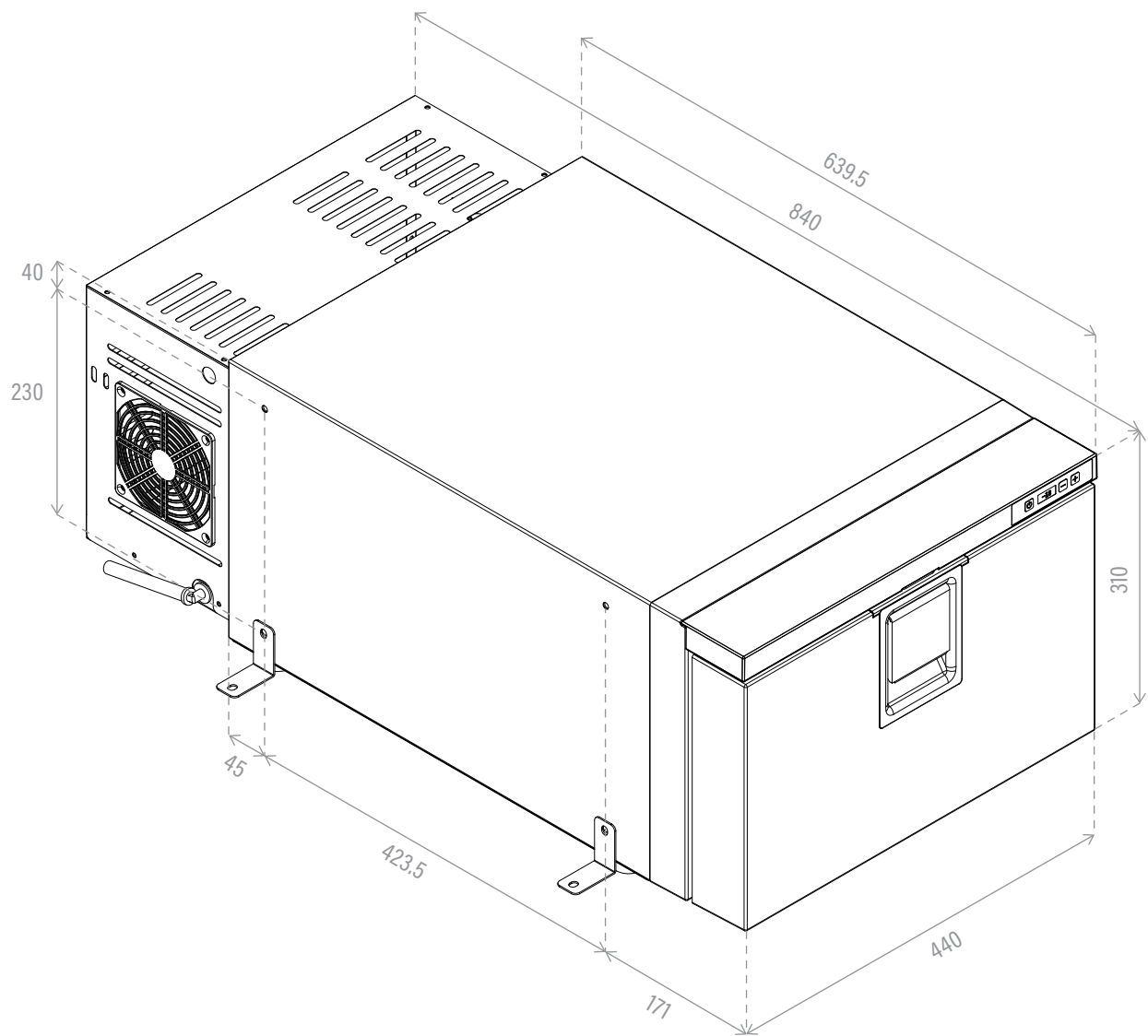



THANKS FOR CHOOSING BUSHMAN, YOU'RE THE BEST!

If you need a hand setting up your fridge, or just want some good, old-fashioned advice, pick up the dog and bone or flick us a message – we'll always get back to you. That's our cast iron promise.



 **100% AUSSIE OWNED
FAMILY COMPANY** | EST 1982

T +61 3 8080 9990

E info@bushman.com.au

bushman.com.au