

DC-X SERIES

DC50-X / DC65-X /
DC85-X / DC130-X

Owners Manual & Operating Instructions

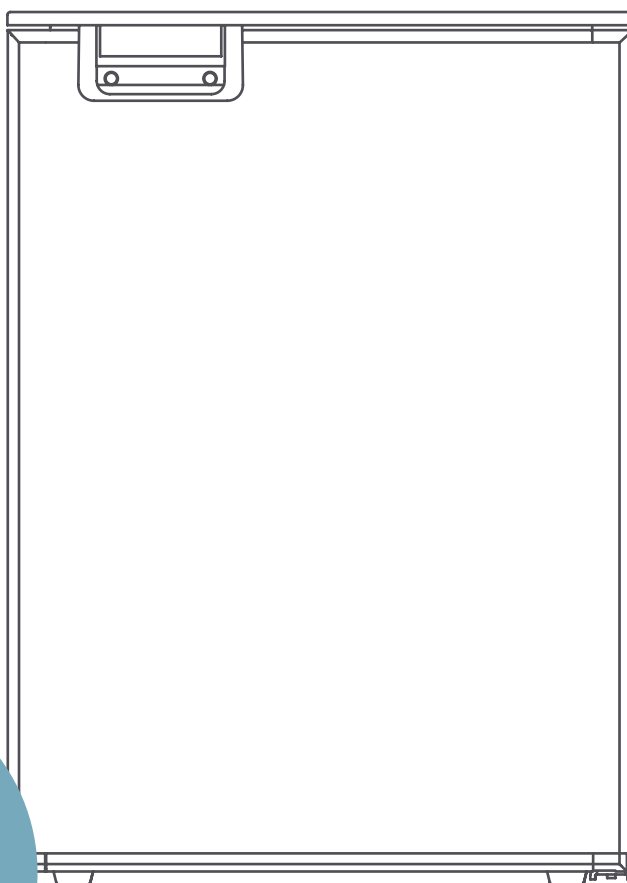

Please read carefully
before use and
installation



100% AUSSIE OWNED
FAMILY COMPANY

EST 1982

Congratulations on your purchase of a Bushman DC-X fridge

Please be safe and use common sense and caution when installing, operating and cleaning this appliance. If you are unsure about any of these instructions, contact your local dealer before proceeding.

Important information

- Do not lay your fridge on its back, top or sides or at any angle exceeding 30°. If your fridge has been incorrectly handled, ensure that the fridge is placed in a level upright position for 12 hours to allow the internal fluids to redistribute evenly.
- Never connect your fridge directly from a 240 V or AC power supply.

Prior to installation

Delivery

At delivery, please check that the fridge is complete and is not damaged in any way. Remove all packaging and securing tapes from the fridge. To avoid injury and causing damage to the appliance, be extremely cautious when using sharp or pointed tools to complete this task. Do not connect an appliance that has been damaged, contact your local dealer immediately.

Installation

Installation of the DC-X range of fridges must be completed by a suitably trained professional only.

Power supply

Your fridge must be connected to a stable and regulated 12 V or 24 V DC power supply. The compressor will automatically detect which voltage is present and adjust accordingly. If you are using a generator or other power supply, the output must be a pure sine wave only, do not use a modified sine wave inverter to operate your fridge.

Wiring

Wire your fridge on a dedicated circuit, directly to your battery bank. For optimum results, do not go via a buss bar, shared circuit, or battery management system. You will need the correct sized wire depending on the distance from your power supply to the fridge. Please also ensure the earth is wired directly to your battery, not to a chassis. If your wiring is insufficient, your fridge may not perform correctly or may be even be damaged.

CROSS SECTION IN MM ²	AWG (AMERICAN WIRE GAUGE)	MAXIMUM LENGTH OF WIRE IN METRES	
		12 V	24 V
2.5	14	2.5	5
4	12	4	8
6	10	6	12
10	8	10	20

We recommend installing an isolation switch for the fridge circuit as close to your battery bank as possible. Any switches must have a breaking load not less than 20 A on 12 V or 10 A on 24 V. The power supply wiring must also be protected with a 15 A fuse.

Ensure the wiring polarity is correct. Connect the red wire to the positive terminal (+) and the black wire to the negative terminal (-). Never connect bare electric wires together. Use only connections of a size suitable for the cross section of the wire being used.

Wire shelves

The wire shelves have slotted runners on each side. These are designed to be bent outwards to provide a snug fit and to stop your shelves moving during transit.

Installation into a cavity

Refer to the following table for the recommended cut-out dimensions. If you are using the mounting kit, allow an extra 5mm width for the mounting kit frame and screws.

MODEL	CUT-OUT CAVITY DIMENSIONS (MM)		
	WIDTH	DEPTH	HEIGHT
DC50-X	385	495	530
DC65-X	455	515	530
DC85-X	480	550	630
DC130-X	530	550	755

Mounting option 1 - Internal sleeves

There are 4 internal sleeves on the inside of your fridge cabinet (2 on each side). You can screw or bolt through these sleeves, from the inside of your fridge out into your cabinetwork.

- Access is provided by gently levering off the plastic caps.
- Only use M5 pan head screws or bolts with the thread type to suit your application.
- Drill 4mm pilot holes through the plastic sleeve from inside of your fridge cabinet, and continue to drill all the way through the fridge cabinet sheet metal sides. The fridge is now ready to go into your cavity.
- Before you insert the screws or bolts, ensure that the exterior of the fridge cabinet is flush with your cavity. If there is a gap on either side, pack it out with timber.
- Once you have fastened your fridge, there are 4 x small, cylindrical foam pieces to be inserted, one into each sleeve before reinserting the plastic cap.

Mounting option 2 – Mounting kit

You will receive a mounting kit (fascia) with your fridge. The mounting kit is affixed to the sides and top of the fridge cabinet using the screws provided.

- a. Be sure to align the mounting kit so it is flush with the front edge of your fridge cabinet before fastening. Do not over tighten.
- b. We do not provide screws to fasten the mounting kit to your cavity, please choose a screw type suitable for your cavity material.

Mounting support – Fridge box

We have partnered with TLX 4x4 in Perth to manufacture aluminum fridge surrounds, commonly referred to as a fridge box. There are three sizes available to fit DC65X, DC85X and DC130X.

Each fridge box comes complete with instructions, all hardware and fasteners needed for assembly. Once you have assembled your fridge box, there are bolt holes on the front and rear lower edges so you can screw it down.

If you have restricted access, you can also drill into the sides of the fridge box to secure it into place.

Mounting options – Custom brackets

Many of our customers make their own brackets to suit their situation. We provide M5 threaded nut inserts and matching bolts with every fridge, fitted to both sides and the rear. You can use these bolts to secure your fridge in any position. We recommend using a minimum of 8 bolts.

Do not screw into other areas on the fridge cabinet!

Ventilation

Ventilation will have a significant impact on the ability of your fridge to cool. A minimum of 2 vents needs to be provided from the rear of the fridge cavity to the outside environment, or to the main room where the fridge is located. The vents must have a free cross section of 400cm² each. Note that a 400mm x 200mm vent has a free cross section of approximately 400 cm² (not 800 cm²). (See page 6).

Important steps for effective operation

Thermostat setting

The thermostat should be set on the lowest number to keep your fridge cold. Start the fridge on setting 2 and wait 24 hours. Only increase the thermostat setting one gear at a time if your drinks are not cold. Setting 2 – 3 is the best. Do not go above 5 as this causes very quick ice build-up.

Equalising the fridge

During the first 24 hours, your compressor will operate for longer than usual whilst the fridge temperature equalises.

Keep hot / wet items out of the fridge

Try and keep hot or wet items out of the fridge as they are a prime source of moisture and ice build-up.

Space items, especially on the top shelf

It's important to keep some space between your items in the fridge so that the cold air can circulate. This is critically important on the top shelf so the cold air from the freezer can fall into the fridge cabinet. Round items like cans and jars are good for the top shelf as they allow space around them. Packets of meat etc are probably the worst items as they create an insulated barrier between the top shelf and the rest of the fridge.

Rubber seals are clean

Keep your rubber seals clean and free from stickiness. You can clean the rubber seals and the front edge of the fridge cabinet with warm, soapy water.

Have goods inside the fridge

The fridge will not operate properly if it is empty, as air does not hold temperature well. If you are using a thermometer the temperature readout will fluctuate significantly when you open the door, whilst your goods inside the fridge will not vary much at all.

Defrosting

Defrosting needs to be carried out when the ice layer reaches a thickness of 5 - 10mm.

Turn off the power to the fridge and move your food and beverages to another cool place.

Do not scrape the freezer to remove ice, it must be allowed to melt naturally.

Thoroughly dry the inside of the fridge and freezer. Re-start the fridge on setting 3 and monitor after 48 hours.

Cleaning

Always keep the inside of the fridge clean and dry. Wash the inside of your fridge with lukewarm water and a mild soap. Never use abrasive or corrosive cleaning agents, steel wool or scouring sponges.

Storage

Keep the door of the fridge ajar when the fridge is not in use to allow fresh air to circulate inside the fridge.

Removing the fridge door - moving the hinges to the opposite side

Your Bushman DCX series fridge comes with the door hinges fitted to the right hand side from factory. You can swap these to the left-hand side.

1. Swapping the hinges

- a. Position the fridge on a bench with the front edge overhanging so you can access the bottom hinge screws.
- b. Unscrew and remove the top metal door catch
- c. Unscrew and remove the top hinge
- d. Gently lift off the main door
- e. Unscrew the bottom hinge. If there is a small washer on the bottom hinge, make sure this doesn't stick to the bottom of the fridge door!
- f. Unscrew and remove the lower door support bar on the left hand side and move this to the right side.
- g. Reposition the bottom hinge on the left side and do the screws up finger tight only for now.
- h. Sit the main door onto the bottom hinge (with the washer).
- i. Affix the top hinge and screws, also finger tight only.
- j. Twist the door anti-clockwise so it is square to the fridge cabinet. Get someone to hold the door in that position and tighten all the hinge screws hand tight. Do not over tighten the hinge screws or they will no longer bite.
- k. Check the door opens and closes freely without rubbing on the lower metal door support. It should sit 1 or 2mm above that metal plate.

2. Moving the door handle

- a. Remove the 2 screws which hold the door handle in place. Access is provided under the logo sticker. You can more easily remove the sticker by applying moderate heat from a hair dryer or heat gun
- b. Gently lift the door handle off
- c. Reposition the door handle on the preferred side.
- d. Drill 2 small (2mm) pilot holes through the door handle and 10mm deep into the door panel (there is a metal sheet behind the door panel that the screws bite into, make sure you drill through this).
- e. Reaffix the door handle using the original screws, hand tight.
- f. Reapply the logo sticker onto the door handle by applying moderate heat to the sticker. We also supply spare door handle stickers with every fridge in the owners manual pack.
- g. Use the supplied DC-X Series sticker to cover the old screw holes.

Adjusting the door latch

Please refit the top metal door catch and tighten the screws finger tight. Move the door catch rail towards the rear of the fridge cabinet until the plastic door latch just makes light contact. If there is more than 1mm of movement, this will need adjusting. Once this is in the right position, do the screws up hand tight. See diagram below:

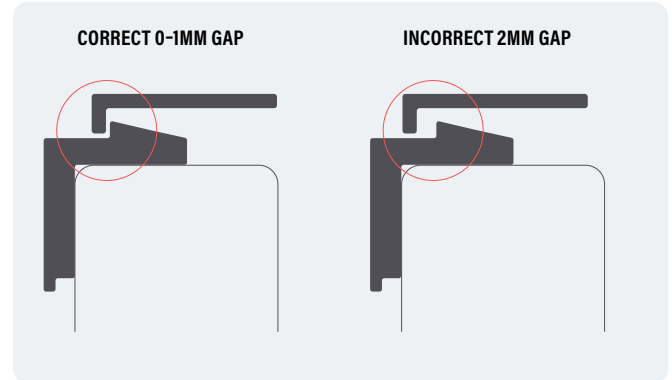

Replacing the front door panel

Follow steps A and B under "Moving the door handle" above.

- a. Gently remove the bottom door profile which supports the door panel. Using a screwdriver gently lever the bottom door profile outwards only. Do not lever it down.
- b. Gently slide the original door panel down and out of the door.
- c. Slide the new door panel upwards and into place.
- d. Reposition the bottom door profile to be flush.
- e. Continue from steps C to G under "Moving the door handle" above.

Rubber door seals

1. It is important that the rubber door seals are making contact 100% of the way around the fridge cabinet.
2. There are magnets inside the rubber seal which pull towards the metal fridge cabinet to keep it airtight.
3. After you have adjusted your door latch, check to see that the rubber seal is making contact with the fridge cabinet on all 4 sides. If there is even a small gap, this will affect the performance of your fridge.
4. With the fridge door closed, start from a corner, gently heat up the rubber seal or light heat from a heat gun (be careful not to overheat the rubber or it will melt). As the rubber heats up, the magnets inside will pull the seal towards the fridge cabinet. Slowly work your way along the rubber from one corner to the other until it is fully sealed. Leave the door closed in this position for 10 minutes for the seal to cool down.

Measurements

MOUNTING KIT
 COOLING UNIT
 SCALE: (MM)

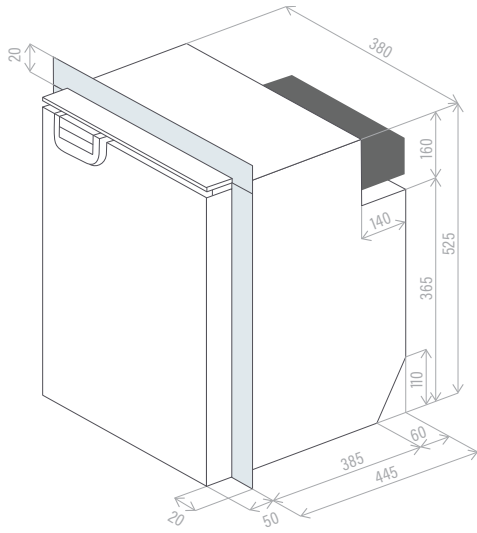

Model DC50-X

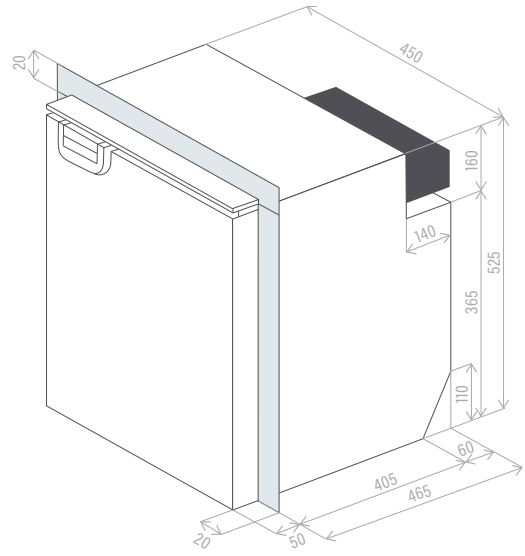

Model DC65-X

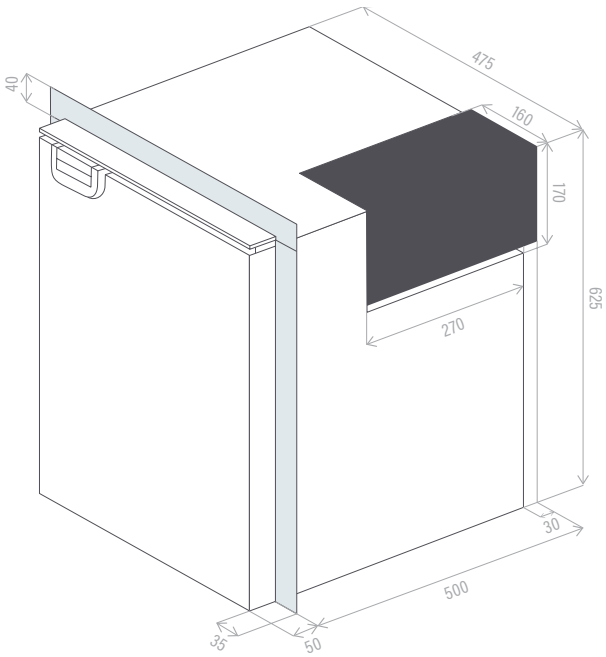

Model DC85-X

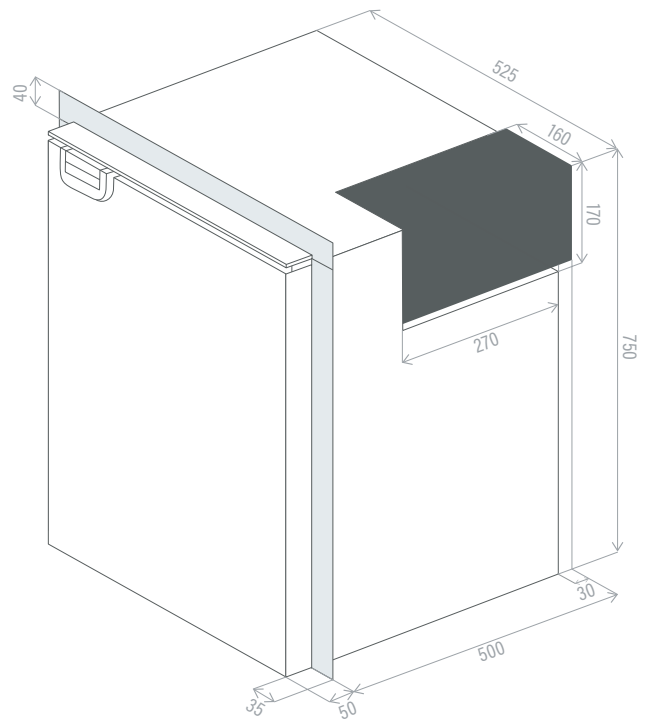

Model DC130-X

Ventilation options

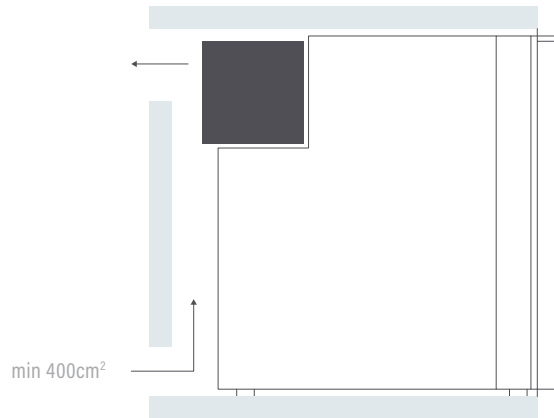

Exterior ventilation

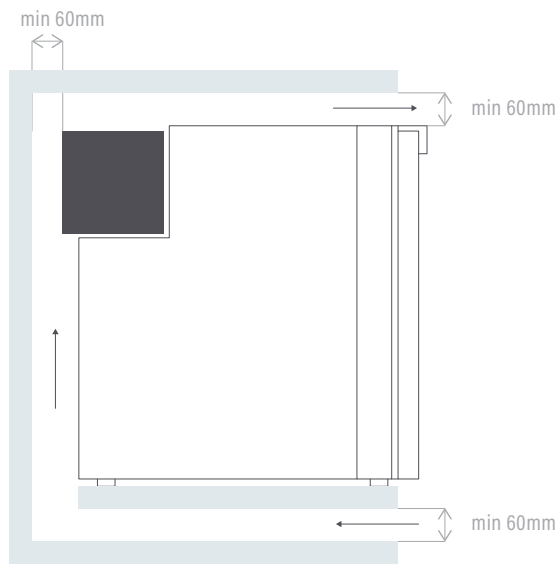

Interior ventilation option 1

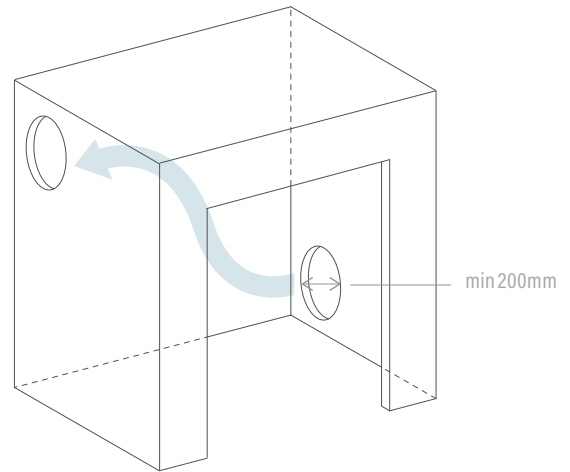

Interior ventilation option 2

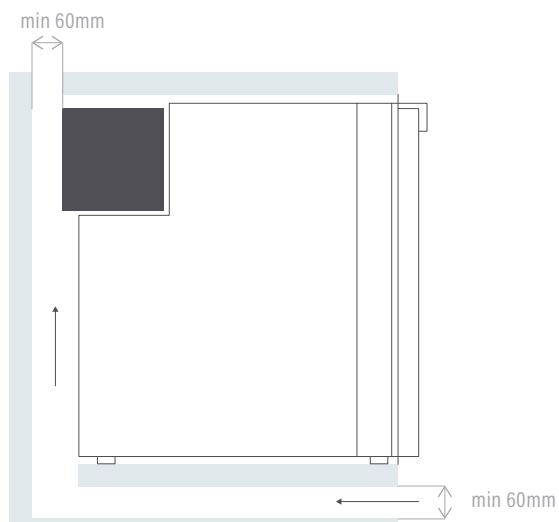

Interior ventilation option 3

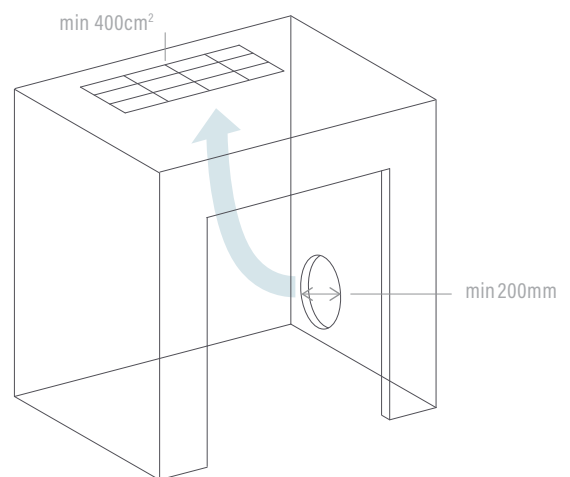

Interior ventilation option 4

Warranty

DP Refrigeration Pty Ltd trading as Bushman Fridges ABN 94 615 295 255 (Bushman) warrants, to the original owner, that this product is free from defects in workmanship and material for a period of three (3) years from the purchase date. This warranty shall be limited to repairing or replacing, at Bushman's option and without charge to the purchaser, defective components. All warranty work shall be performed at a Bushman approved facility. Shipping charges related to returning the product to the Bushman facility are not covered under this warranty. However, this warranty covers shipping charges related to returning the repaired product to the customer. This warranty does not apply to damage or wear to the product caused by accident, abuse, misuse, neglect, unauthorized alteration or repair, or if the product was not used in accordance with Bushman printed installation and operating instructions. To obtain service under this warranty, the defective product must be returned to Bushman together with a copy of the original purchase receipt. Any product repaired or replaced under this warranty will be warranted for the balance of the warranty period with respect to the original purchased product. Bushman is not liable for any incidental or consequential loss or damages whatsoever because of use or misuse of this product. Any statutory warranty also applies.

Troubleshooting

Please check each of these 4 points. All 4 need to be right for your fridge to operate correctly.

1. Voltage

The most common cause of an incorrectly functioning fridge, or a fridge that starts and stops and doesn't get cold, is a lack of consistent voltage. Danfoss compressors have built in battery protection and need the following minimum voltage for the compressor to start (Cut-in) or to continue running (Cut-out).

VOLTAGE	CUT OUT	CUT IN
12 V	10.9 V	9.6 V
24 V	22.7 V	21.3 V

Note that when the compressor starts it will draw up to 10 A for 12 second to turn the compressor over. When this 10A load is applied, the voltage can drop significantly, causing the compressor to turn off again.

This often happens at night when the battery gets a bit lower (no solar input) or when the car alternator hasn't been started for a while (no alternator input) or if there is a weak spot somewhere in the electrical system (weak join, weak solder, undersized wire, worn battery).

To isolate this problem, use a different, direct power supply as follows:

Connect the red and black power wires from the compressor directly to a different 12V power source (for example a fully charged deep cycle 12V battery). It is important to run these two wires directly to the power source, without any unnecessary connections, plugs, solar, battery management, power distribution or buss bars. If the fridge now runs correctly, there is a power supply issue somewhere.

Get an electrician to check

- The polarity of the connections are correct
- The wiring between the fridge and battery is correctly sized (see page 2)
- Any connections or joins in the wire between the fridge and the power source are 100%
- The battery is not wearing out and is capable of consistently providing 12 volts when a 10 amp load is placed on it
- The voltage to the compressor is still 12V when a 10 A load is placed on the wires

2. Ventilation and airflow

- There is adequate ventilation and free air flow to the compressor area (see page 3 and 6)
- The fridge is not installed in a sealed cavity, container or canopy
- The condensor fan is operating

3. Ice build-up

Ice will slowly build up on the freezer section over many weeks. This is a normal part of the operation of a low-power cooling system. Excessive ice build-up is a problem as the ice eventually insulates the cooling element and hinders the fridge's ability to cool. In this instance, turning the thermostat up to flat out (6 or 7) will cause ice to build up even faster. Therefore, slowing the ice build-up from the start is the key. Please follow these 4 steps:

- a. Check the rubber door seal is touching the fridge cabinet all the way around on all 4 sides (see page 4)
- b. Check the door closes freely without rubbing on anything (see page 4)
- c. Check the door latch has a tight fit when closed (see page 4)
- d. Defrost the fridge, dry it out and start again on thermostat setting 3 (see page 3)

4. Fridge operation

- Space items in the fridge, this is critically important on the top shelf - (see page 3)
- Set the thermostat to the lowest number possible (see page 3)
- Only open the fridge or freezer door for short periods of time and when necessary
- Do not place hot or wet items inside the fridge

Red LED error light

From mid 2021 onwards all Bushman DC-X series are fitted with a red LED error light.

- Mid 2021 – mid 2022 the red LED is located on the compressor module.
- Mid 2022 onwards the red LED is located inside the interior light housing.

The number of flashes corresponds to the following error type.

NO. OF FLASHES	ERROR CODE
1	Battery protection cut-out The voltage is outside the cut-out setting [LOW VOLTAGE].
2	Too many start attempts (or fan over current) This generally indicates the compressor has had too many start attempts due to battery protection cut-out [LOW VOLTAGE]. It could also indicate fan overload of more than 0.5A but this is extremely rare.
3	Motor start error The rotor is blocked or the differential pressure in the refrigeration system is too high (>5 bar)
4	Minimum motor speed error Refrigeration system is overloaded, and motor cannot maintain minimum speed (1850 rpm)
5	Thermal cut-out Refrigeration system overloaded or ambient temperature is too high.
6	Thermostat failure The NTC thermistor has a short circuit or no connection.

Technical specifications

	DC50-X	DC65-X	DC85-X	DC130-X
COMPRESSOR	SECOP BD35	SECOP BD35	SECOP BD35	SECOP BD35
VOLTAGE	12 V / 24 V DC	12 V / 24 V DC	12 V / 24 V DC	12 V / 24 V DC
WATT RATING	60 W	60 W	60 W	60 W
EXTERNAL DIMENSIONS MM	W 380 D 495 H 525	W 450 D 515 H 525	W 475 D 550 H 625	W 525 D 550 H 750
NET WEIGHT	16.4 KG	18 KG	22.5 KG	27.2 KG



T +61 3 8080 9990

E info@bushman.com.au

bushman.com.au